

Implementing water allocation in the TIAM-FR energy model

Bouckaert Stéphanie, Selosse Sandrine, Dubreuil Aurélie, Assoumou Edi, and
Maïzi Nadia

Centre for Applied Mathematics, MINES ParisTech
Chair ParisTech Modeling for sustainable development

11th IAEE European Conference
August 28



- 1 Overview
- 2 Water in electricity production
- 3 Implementation in TIAM-FR
- 4 Results
- 5 Conclusion

Policies dealt separately but... interdependency

Growing issues for water and energy

- Energy sector: depletion of fossil resources, environmental impacts
- Water supply: availability and sustainability of water resources



Policies dealt separately but... interdependency

Growing issues for water and energy

- Energy sector: depletion of fossil resources, environmental impacts
- Water supply: availability and sustainability of water resources

Water for energy

- Cooling systems
- Hydropower
- Extraction and mining
- Fuel production
- Emission controls



Energy for water

- Pumping
- Transport
- Treatment
- Desalination

Increase of water uses

Basic knowledge

- **Withdrawal:** water removed from any sources, either permanently or temporarily
- **Consumption:** part of withdrawal which is no longer available for utilization

Increase of water uses

Basic knowledge

- **Withdrawal:** water removed from any sources, either permanently or temporarily
- **Consumption:** part of withdrawal which is no longer available for utilization

World withdrawals

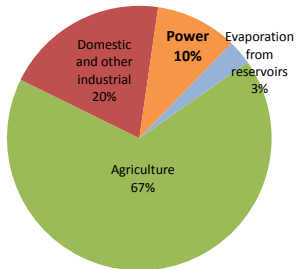

World consumptions

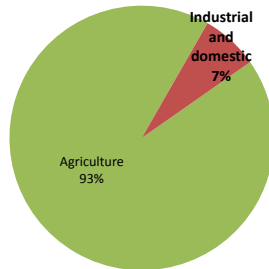

Water in electricity production

Water uses: water factors

- 1 Main loop < 1 %

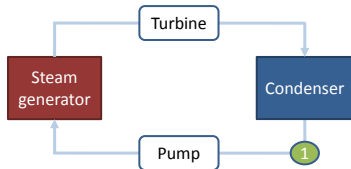

Water in electricity production

Water uses: water factors

- 1 Main loop < 1 %
- 2 Cooling systems

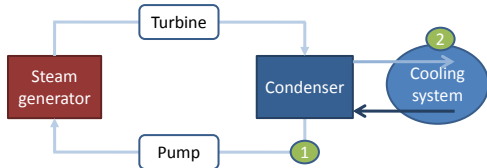

Water in electricity production

Water uses: water factors

- 1 Main loop < 1 %
- 2 Cooling systems
▶ C
- 3 Gasification process

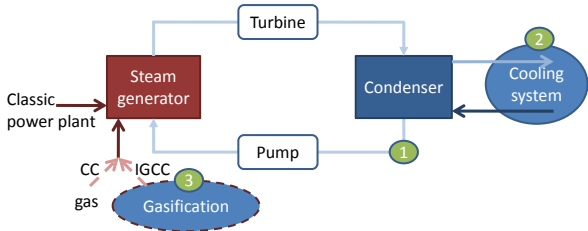

Water in electricity production

Water uses:

water factors

- 1 Main loop < 1 %
- 2 Cooling systems
▶ C
- 3 Gasification process
- 4 Emission controls

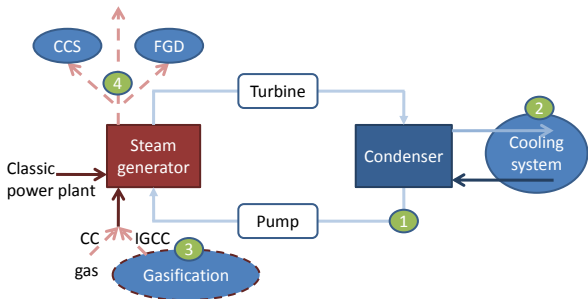

Cooling systems

Open loop

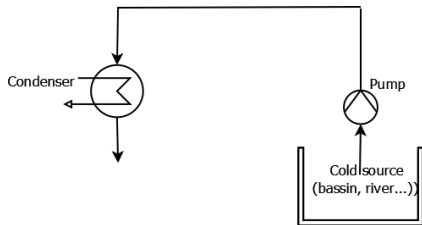

► R

Closed loop

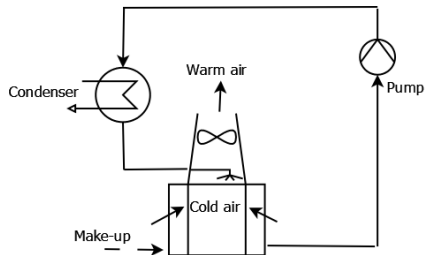

Water in electricity production

Water uses:

water factors

- 1 Main loop < 1 %
- 2 Cooling systems

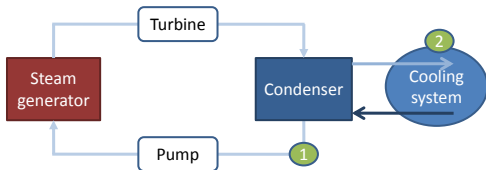

Water in electricity production

Water uses:

water factors

- 1 Main loop < 1 %
- 2 Cooling systems
- 3 Gasification process

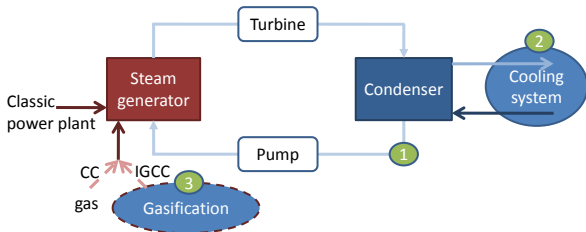

Water in electricity production

Water uses:

water factors

- 1 Main loop < 1 %
- 2 Cooling systems
- 3 Gasification process
- 4 Emission controls

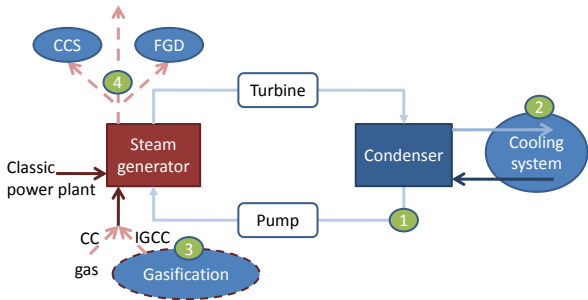

- Carbon capture and storage (CCS)
- Flue gas desulfurization (FGD)

TIAM-FR model: long term planning tool

- TIMES Integrated Assessment Model developed by ETSAP (Energy Technology System Analysis Program)
- Technology-rich representation of the energy systems: bottom-up model
- Global model: 15 regions
- Long-term development of the energy system (2005-2100)
- Technical optimum: minimizing the discounted global cost

Scenarios

Scenarios for new installations.

No change of existing power plants water factors.

- BAU (Business as usual scenario): Water factors for new installations = Water factors for existing installations
- CL: new installations use only closed loop systems (better efficiency enables to decrease the temperature difference)
- CL+NE: new installations use only closed loop systems and better efficiency allows decreasing the flow needed in the cooling system

Worldwide electricity generation by source

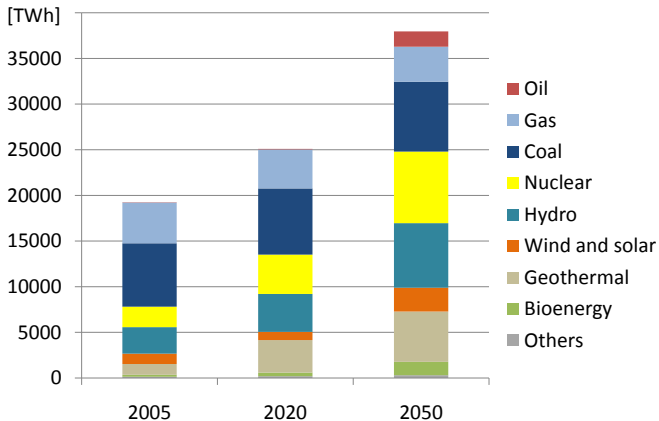

Water shares

Withdrawals

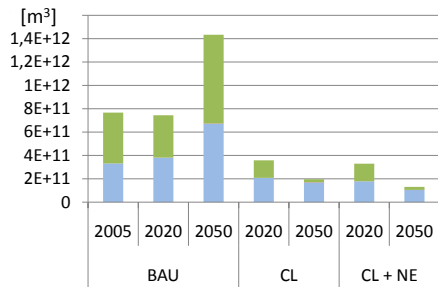

Consumptions

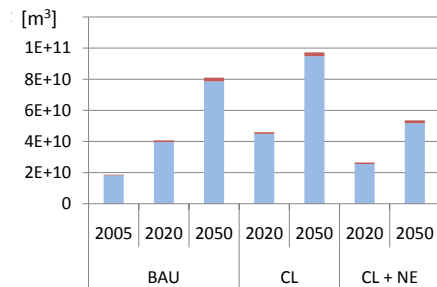

■ Brackish and saline water

■ Fresh water

■ FGD Needs

Focusing on fresh water

Withdrawals

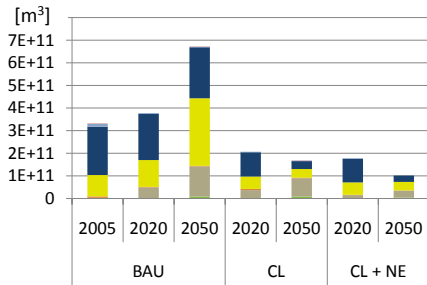

Consumptions

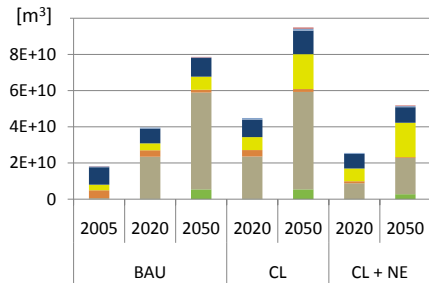

Oil

Gas

Coal

Nuclear

Solar

Geothermal

Bioenergy

Water specificities

FGD water footprint

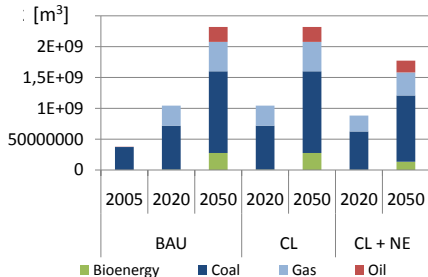

Water specificities

FGD water footprint

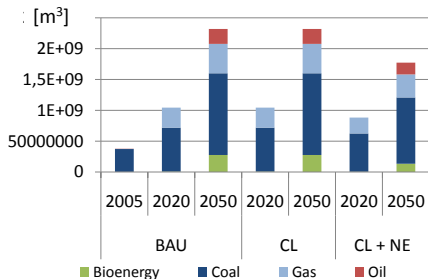

Focusing on coal

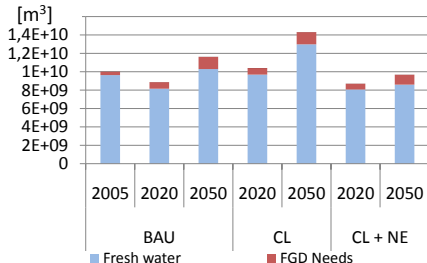

Conclusion

This water-energy model could enable finding a global optimum between these two essential resources!

Strategic factors

- New installations: some have a major water footprint
- Better efficiency
- Cooling systems
- Emission control: FGD (+10%), CCS(+90%)

Further analysis

- Evaluation of the CCS technology water footprint
- Extraction, beneficiation . . . of fossil source
- Biofuels

Thank you for your attention !

Reference Energy System : RES

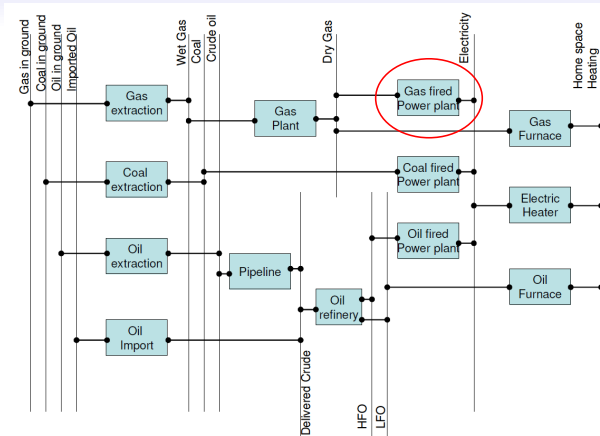

Documentation for the TIMES Model, Loulou and al

Reference Energy System : RES

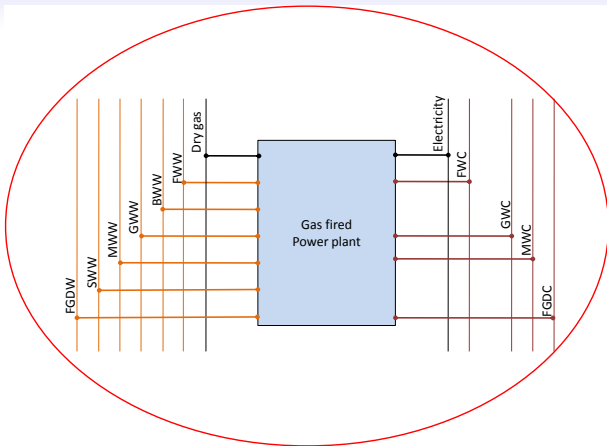

Implementation of water factors for each technology concerned

Implementing water allocation in the TIAM-FR energy model